



MANIFOLDS

DESCRIPTION

The Fike ProInert Manifolds are offered in 2, 3, 4 and 5 cylinder configurations. For systems that require more than 5 cylinders, manifolds must be interconnected into a common feed pipe.

Each manifold comes pre-assembled and includes the following parts:

- 25mm Galvanized Equal Tee
- 25mm Galvanized Pipe

Installation

All pipe connections to be made with sealing tape. Manifold supports are supplied by others. It is recommended to use vertical Unistrut with cantilever brackets for manifold supports.

SPECIFICATIONS

- Part Numbers::
 - IG71-004-2 (2 Cylinder Manifold)
 - IG71-004-3 (3 Cylinder Manifold)
 - IG71-004-4 (4 Cylinder Manifold)
 - IG71-004-5 (5 Cylinder Manifold)
- Pipe and Fittings: Galvanized
- Pipe Specification: BS 1387 Heavy/ASTM A-106A, Schedule 40/80
- Fitting Specification: EN 10241 Seamless Test Pressure 150 bar
- Pipe Threads: R1 ISO 7

NOTE: All Tee center to center dimensions are 282 mm

APPROVALS



Certification Number 654a

5 CYLINDER MANIFOLD , 25mm NB

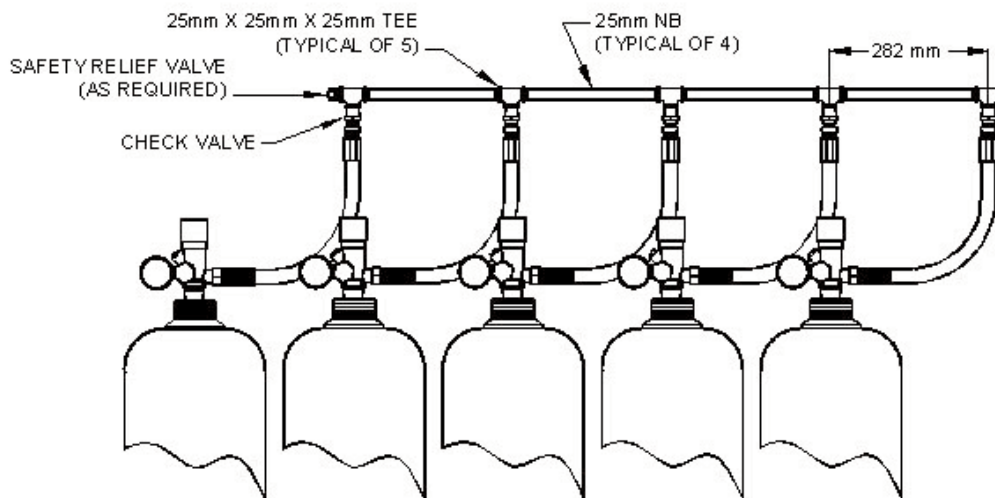

This page intentionally left blank

